

User Manual

Waterproof Indicator

QW/GW with

Multicolor Backlight

© Excell Precision Limited. All rights reserved Worldwide.

The information contained herein is the property of Excell Precision Limited and is supplied without liability for errors or omissions. No part may be reproduced or used except as authorised by contract or other written permission. The copyright and the foregoing restriction on reproduction and use extend to all media in which the information may be embodied.



6F, No. 127, Lane 235, Baoqiao Rd., Xindian District,
New Taipei City 23145, Taiwan



pm-all@excell.com.tw



+886-2-8919-1000



<https://www.excell-scale.com>



+886-2-8919-2209



Table of Contents

Table of Contents	1
SPECIAL NOTICE	3
Before Using the Scale	4
Instruction for Use	4
Preparing to use the Scale	4
Chapter 1 Introduction	6
1-1 Product Features	6
1-2 Specifications	6
1-3 Product Appearance	6
1-5 Power Supply	8
1-6 Keypad Function	9
1-7 Error Messages	11
1-8 Weight Units	12
1-9 Self-Test Mode	12
Chapter 2 Configurations	14
2-1 01 FnC General Function Setting	14
2-1-1 FnC 01 Auto Backlight	15
2-1-2 FnC 02 Auto Power-off Timer Setting	15
2-1-3 FnC 03 HI/LO/OK Settings	15
2-1-4 FnC 04 Restore to the Default Settings	16
2-1-5 FnC 05 Noise Filter Settings	16
2-1-6 FnC 06 Hold Function Settings	17
2-1-7 FnC 07 Auto Unit Weight Averaging Setting	19
2-1-8 FnC 10 Record Last Zero	19
2-1-9 FnC 11 Foot Switch Settings (Option)	19
2-1-10 FnC 12 [F] Key Function Settings	20
2-1-11 FnC 13 Zero Key Setting	20
2-1-12 FnC 14 Backlight Color Setting	20
2-1-13 FnC 15 Backlight Brightness Setting	20
2-2 02 EC External Weight Calibration	21
2-3 03 rS1 RS232 Serial Interface Settings	22
2-3-1 rS1 01 Baud Rate Settings	22
2-3-2 rS1 02 Communication Protocol Settings	22
2-3-3 rS1 03 Output Format Settings	23
2-3-4 rS1 04 Transmission Method	26
2-3-5 rS1 05 Continuous Transmission Rate	26
2-3-6 rS1 06 Zero Band Setting for Auto Transmission	26
2-3-7 rS1 07 Weight Band Setting for Auto Transmission	27
2-3-8 rS1 08 Output Condition Settings	27
2-3-9 rS1 09 RS232 6/7 Digits Setting	27
2-3-10 rS1 10 RTC Adjustment	28
2-3-11 rS1 11 Y/M/D Print Format	28
2-3-12 rS1 12 RS485 ID Input (Option)	28
2-3-13 rS1 13 Numbers of Line Feed for rS1 03 = 10 or 11	28
Appendix 1 ASCII Code Table	29
Appendix 2 7-Segment Display Characters	29
Appendix 3 RS-232 Data Format	30
Appendix 4 Wiring Instructions	35



Check Firmware Version

Turn off scale first. Hold **NET|GROSS** key and press **ON|OFF** key to turn on scale. Wait till display shows 01 AdC. Press ZERO key twice and display 03 VEr. Press **TARE|PT** key to display firmware version 02005. Press **TARE|PT** key again to display maintenance number 60X (X is ranged from 0~9) for 2 seconds. Turn off and turn on scale to return to weighing mode.



SPECIAL NOTICE

While installing the load cell, power cord hookup or replacing a new rechargeable battery, the indicator housing must be opened. It must be done by a technician assigned by your electronic indicator provider to avoid affecting the waterproof ability of this indicator. Before opening the housing, make sure the indicator is dry, if there is any liquid on it, please wipe it with a clean cloth.

How to INSTALL THE HOUSING:

After installing the load cell, power cord hookup or replacing a new rechargeable battery, the housing must be screwed by the assigned order as shown below. Screw lightly first, then screw them tight using a 6 kgf-cm (GW) or 12 kgf-cm (QW) torsion.

P.s. Please use a torsion-adjustable screw driver.

Screwing order:

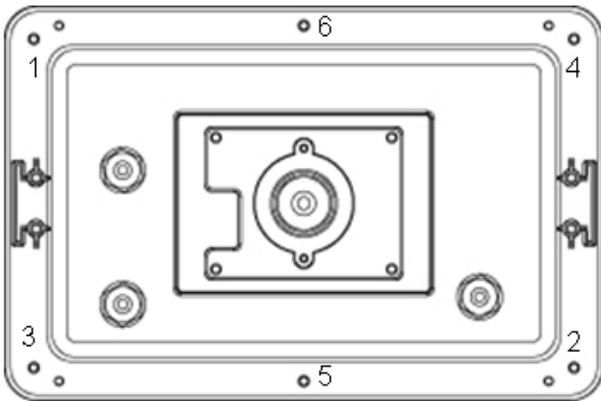

▲ GW

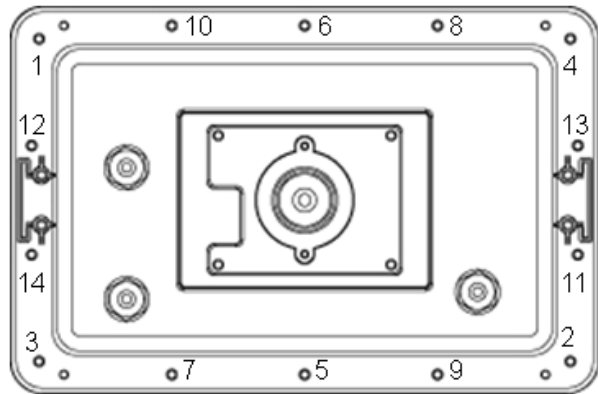

▲ GW

▼ How to Install U-Bracket

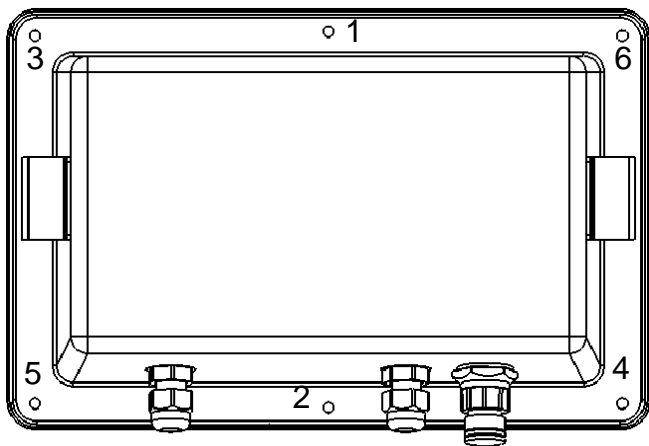

▲ QW

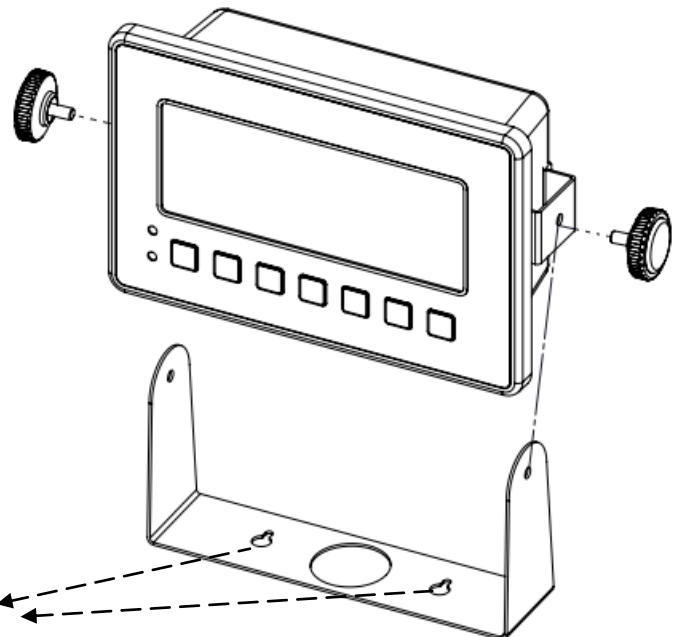

M8 Recommended
Screws are **NOT** included



Thank you for purchasing EXCELL WEIGHING INDICATOR, to help use the product properly, operate smoothly, and extend its life cycle, please read this manual carefully.

Before Using the Scale

In order to use this scale correctly, we suggest that you read this manual carefully.

Instruction for Use

1. The load placed on the weigh pan must NOT exceed the maximum weighing capacity of the scale.
2. Protect the scale from high temperatures.
3. Avoid objects impacting with the scale. Do not drop loads onto the scale or subject the weigh pan to any strong shock loads.

Preparing to use the Scale

1. Locate the scale on a firm level surface free from vibrations for accurate weight readings.
2. Adjust the four levelling feet (if fitted) to set the scale pan level.
3. Avoid operating the scale in direct sunlight or drafts of any kind.
4. If possible avoid connecting the scale to ac power outlet sockets which are adjacent to other appliances to minimise the possibility of interference affecting the performance of the scale.
5. Remove any weight that might be on the weigh pan before the scale is switched on and avoid leaving weight on the pan for long periods of time
6. All goods weighed should be placed in the centre of the weigh pan for accurate weighing. The overall dimensions of the goods being weighed should not exceed the dimension of the weigh pan.
7. Once the scale has been powered on, it will go through an LCD display test and it is ready for use when the display shows zero.
8. The scale requires 15~20 minutes warm up before operation to ensure best accuracy
9. Please note when the  symbol keeps flashing on the screen, the batteries need to be recharged.
10. Introduction of Storage Battery



Due to the storage battery adopt the advanced free-maintaining technique, customers need not to replenish electrolyte.

The scale should be recharged every 3 months to prevent failure of the internal rechargeable battery.

1. The battery should be charged for 8~10 hours.
2. The temperature of battery should below 45°C.

Maintaining

1. Please do not discharge with over-current when using the battery. Please charge the battery after discharging current.
2. Please take down the battery when the scale is not used for a long time or break the connection of cathode.
3. Do not short the battery terminals to check whether there is current. Please check whether the connection point is firm to guarantee good connection.
4. The battery should be replaced by specialized person. **No reverse-battery or the product will be damaged.**
 - a) Anode of battery should be connected with Anode of product battery (usually red cable)
 - b) Cathode of battery should be connected with Cathode of product battery (usually brown cable or black cable)
 - c) See the picture following

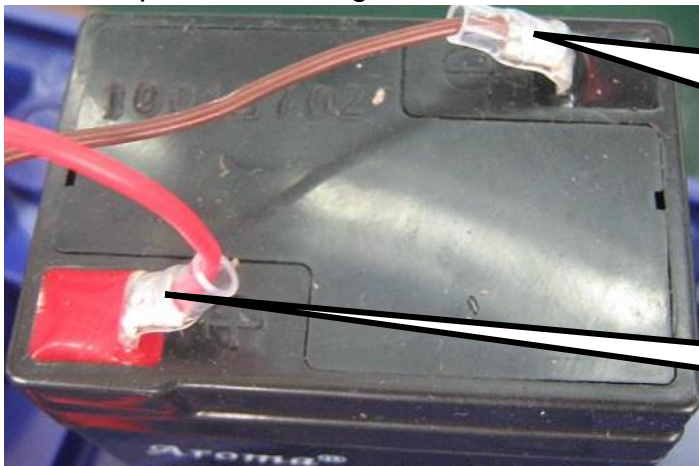

Brown cable(or black cable) connected with Anode of battery

Red cable connected with Cathode of battery

Safety Warnings

1. The electrolyte of battery is caustic which causes metal, cotton, etc. to corrode.
2. The hydrogen will be resolved when using or charging the battery and it will cause explosion when approaches fire.



No burning



Caution Corrosion



Warning Explosion



Children Faraway



Chapter 1 Introduction

1-1 Product Features

- Extra-large and wide LCD display (175 x 70mm) 6 digits with 55mm height for easy weight reading
- Multi-color backlight
- QW with 304 stainless steel housing while GW with plastic ABS housing.
- Sealed to IP68, Waterproof, mist-proof and dustproof (Only use cables of 3mm~5mm diameter to ensure correct sealing of the cable glands)
- Large buttons easy to access and control.
- Kilogram (kg) and pound (lb) weighing modes
- Full range tare; Pre-tare; Auto zero tracking; Sampling counting
- Gross/Net indication
- Hold function; Check mode Lo/Hi/OK with multi-color backlight; Auto average unit weight
- Adjustable gravity value
- Low power indication and auto power off
- AC/DC power in and rechargeable battery
- Built-in RS-232
- Options:
 - One of RS-485, WIFI, Bluetooth,
 - Pressure release valve,
 - Foot switch

1-2 Specifications

- Analogue Input: Input Sensitivity 0.2 μ V/d (Min.)
- Input Signal Range: -1mV~+14Mv
- Input Zero Range: -1mV~+5mV
- Load Cell Excitation: 5V DC
- Load Cell Drive Capacity: Up to 8 x 350 Ω load cells
- Non-linearity: 0.01% of full scale
- A/D Resolution: 500,000 counts (Maximum)
- Operating temperature: -10 $^{\circ}$ C ~ +40 $^{\circ}$ C

1-3 Product Appearance

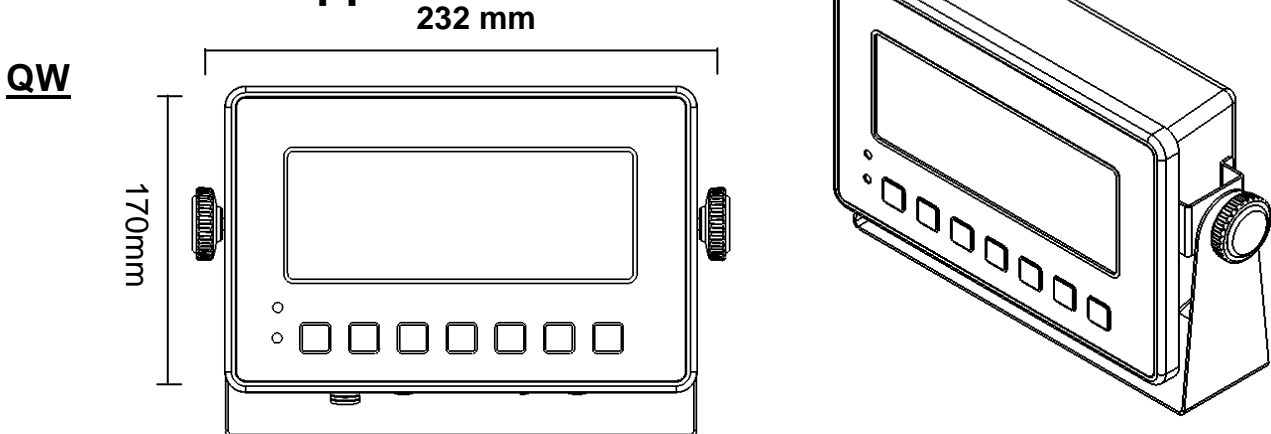



[Standard]

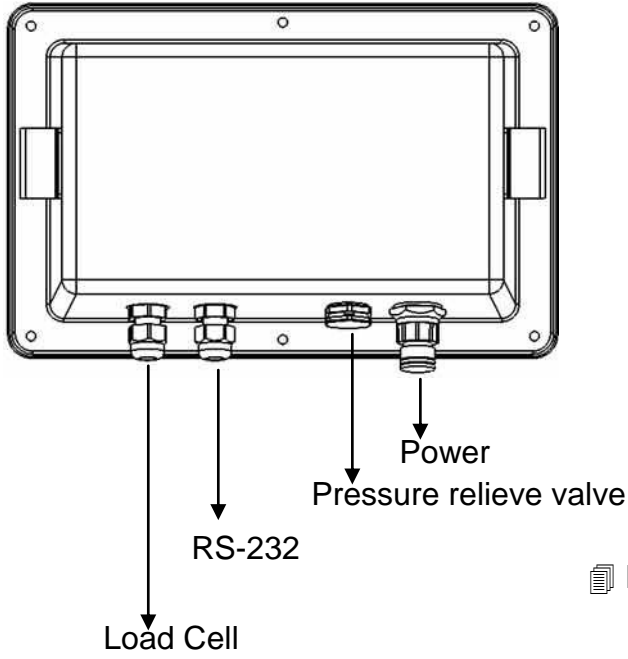

☞ RS-485 is an option

GW

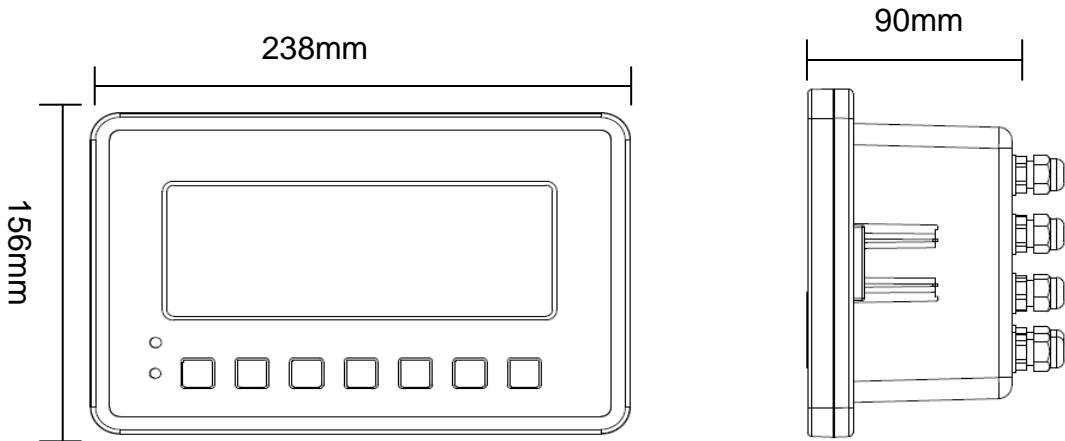

[Standard]

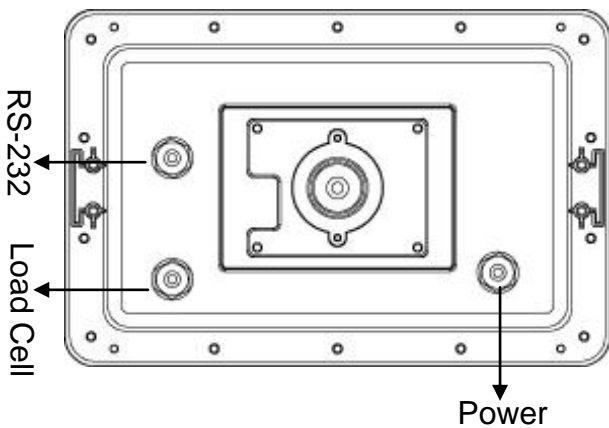

[Option]

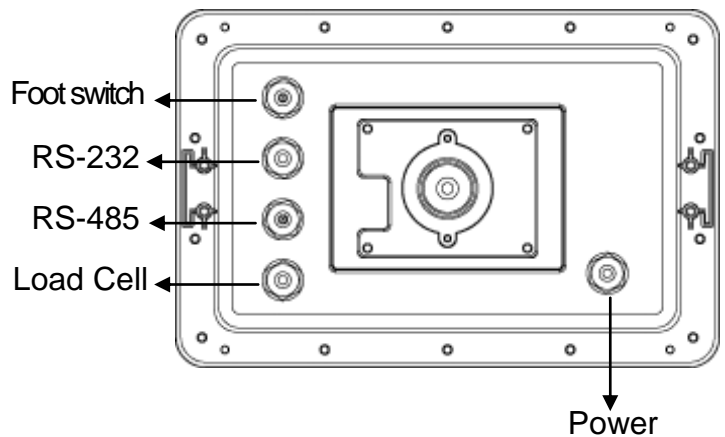

☞ RS-485 and foot switch are options



1-4 Display Description

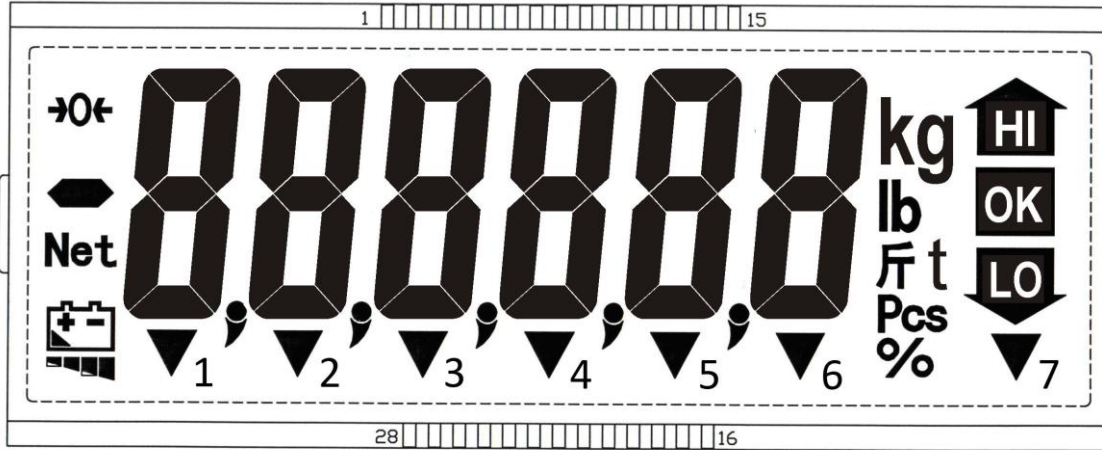

- HI : Upper limit
- OK : Value between HI and LO
- LO : Lower limit
- kg : Unit “kilogram”
- lb : Unit “pound”
- 斤 : HK tael or Taiwan Tael
- Pcs : Counting mode indication
- 0← : Zero point indication
- Net : Net weight indication
- : Low Power indication

Non-approval model:	
▼1	: (STABLE) stable indication
▼2	: (GROSS) gross weight indication
▼3	: () insufficient unit weight
▼4	: (PT) pre-tare indication
▼5	: (Hold) weight hold indication
▼6	: “M+” indication or “GN”, “dwt”, “carat” unit indication
▼7	: Blank or “oz” or “viss” unit indication (set as needed)

Approval model:	
▼1	: (STABLE) stable indication
▼2	: (GROSS) gross weight indication
▼3	: () insufficient unit weight
▼4	: (PT) pre-tare indication
▼5	: Range 2
▼6	: Range 1
▼7	: M+

1-5 Power Supply



Power	Battery	6V 4Ah Rechargeable battery			
	Plugged in	100V~230V AC			
Power consumption (mA) with 1X350Ω load cell	No backlight	30~35			
	White backlight	100%	75%	50%	25%
		140	105	80	55
	Yellow backlight	96			
	Green backlight	62			
	Red backlight	66			

Charging Voltage
DC 12V/1A adaptor



Battery Status and Low Battery Warning

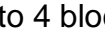

Normal battery status: The () symbol is displayed steadily, indicating current battery status from 1 block () to 4 blocks ().

☞ When the battery status indication is full, the power is about 6.4V; Each block is about 0.2V increment/decrement.

Low battery warning: When the () symbol keeps flashing on the display (the remaining power is about 5.6V), the internal battery should be recharged.

☞ The scale will turn off automatically after a period of nonuse when the low battery warning symbol shows up. The scale must be fully charged, before operating again.

Safety Reminder:

- Please make sure “+” , “- “ poles are placed in the correct direction
- Please don't place the battery in hot areas, or try to disassemble the battery, to avoid electricity leakage.
- The battery inside the indicator was used for testing the fullness of the product. Therefore, the life of the battery cannot be count from the day you purchase.

1-6 Keypad Function

ON/OFF KEY

Press the  key to switch the indicator on or off.

UNIT KEY

Press the  key to switch weight units; the display icons will indicate the active units.

☞ After scale is powered on, scale uses the last used weighing unit.

ZERO KEY

The  key acts as the zero balance function. If the weighing value is within the range of zero balance, it can be re-zeroed and tare cancelled.

☞ Zero Range : OIML&NTEP is $\pm 2\%$ F.S., and Sri Lanka is $\pm 3\%$ F.S.

M+/PRINT KEY

Totalization function. M+/Print function is available when RS232 is on keypad transmission mode. (rS1 04 output).

This key is a composite key, while totalization is shown and weight returns to net zero, press M+ key to erase memory. RS232 will output MC print format (rS1 03 output).

☞ If there is new weight added on platter (it is less than 20 divisions in Brazil version, no accumulation), a new item will be added to totalization. If this weight is not taken off, nothing can be added to totalization. Display will show the totalization numbers for one second, then show net weight for one second, then the scale returns to the current weight, and prints out the last item for totalization.

☞ To clear totalization data, press M+ key to let display shows up totalization numbers, then press the  key again, to clear totalization data. RS232 will print out totalization numbers, total weight, etc.

P.s. Weight must return to net zero if to perform clear function.



TARE|PT KEY: Tare / Pre-tare key

To TARE:

Place the container onto the scale, until the weight value is stable, press **TARE|PT** key for zero return and the NET indication is shown on the display. Place the object onto the container and the display shows the net weight value of the object. Remove both object and container, and negative value of the container will show on the display. Press **TARE|PT** key again to clear "tare value". The scale returns to zero and NET indication goes off.

- Tare can be continuously done until tare value=full load capacity
- Continuous Tare → Press **TARE|PT** key for continuous weight increase/decrease on platter.
- If there is Tare, the pre-tare cannot be done. If there is pre-tare first, and the tare weight more than pre-tare weight, Tare can be done.
- No Tare can be done under gross weight display mode.

NET|GROSS KEY: In the Tare mode, "Net weight" shows on the display and "NET" icon is on; press the **NET|GROSS** key to switch to display "Gross weight". "GROSS" arrow ▼ shows up and only **NET|GROSS** key works here. All other keys become inactive. Gross Weight = Tare weight + Net weight.

To PRE-TARE:

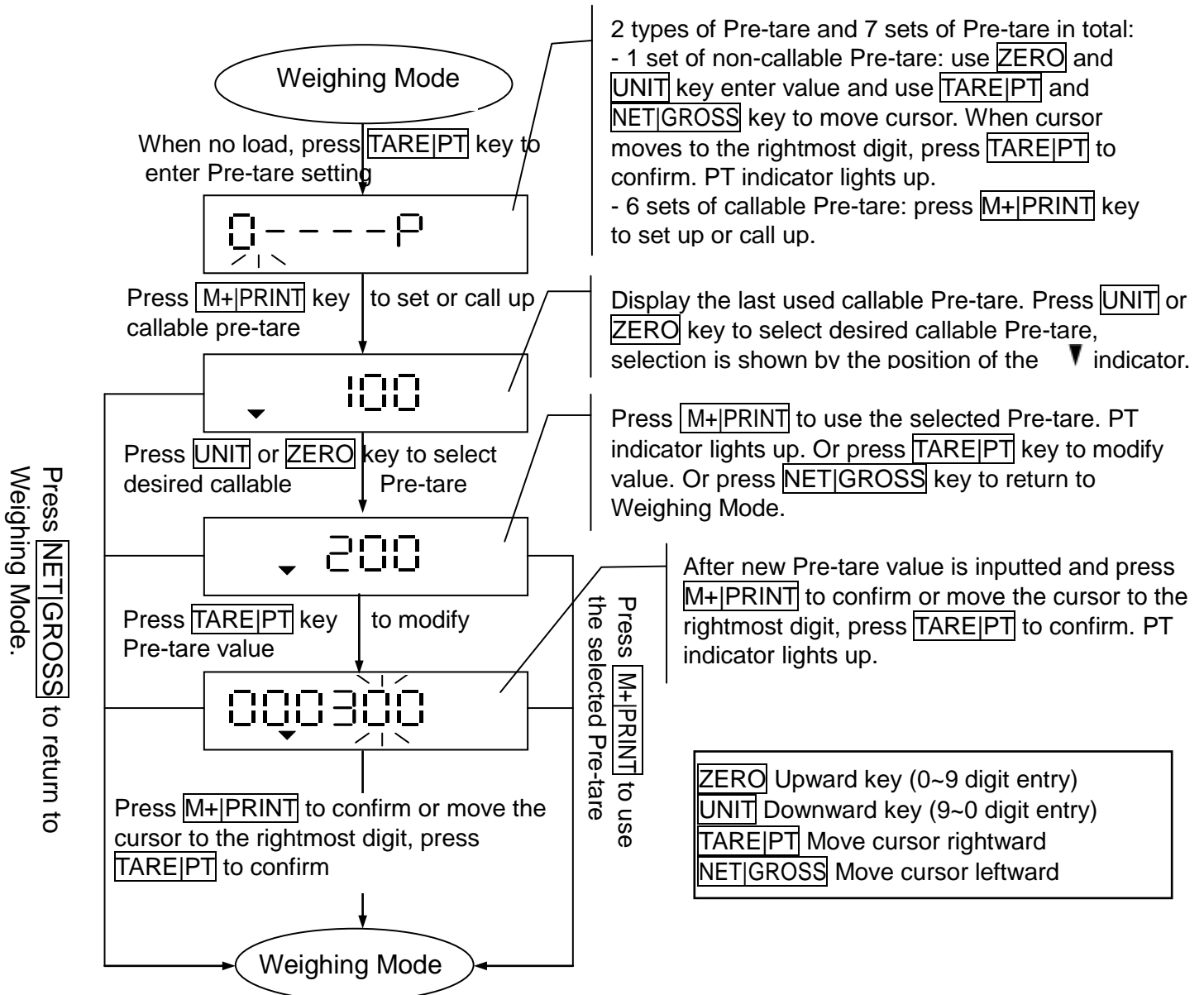

Both types of Pre-tares can be cancelled by press **TARE|PT** key when no load.



F KEY (Non approval models. For approval models, use **F/HR** key instead)

Before using this key, need to go to FnC 12 to set **F** key as the following function.

“MC” (Memory Clear) key: press it to erase memory directly without display the tantalization data. RS232 will output MC print format (rS1 03 output). Note: Weight must return to net zero if to perform clear function.

“HR” (High Resolution) key: press it to display 10 times resolution for 10 seconds and then return to normal resolution. If the original resolution is > 6000, “High Resolution” is not recommended since the reading might be unstable or the number of digits exceed display range.

“T-TP” key: press it to display Tare or Pre-tare value for 2 seconds if they exist and then return to current weight resolution. If both exist, it will display Pre-tare value and then display Tare value.

Foot Switch Mode

This function is optional. Use FnC 11 to select **TARE|PT** key as “ZERO” or “PRINT” key

- ☐ If “PRINT” key is set (rS1 03 = 10 or 11), all totalization data will be printed out, and totalization will be cleared.
- ☐ If it is Brazil version and foot switch is set as Print function, it has totalization function and print function.

Simple Counting Mode

Use **UNIT** key to switch unit to Pcs, to go into simple counting mode.

1. Use **NET|GROSS** key (For approval models, use **NET|B/G** key instead), to select a sample number from “10, 20, 50, 100, or 200”. Display will show **10**, **20**, **50**, **100**, **200** in an sequential order by pressing **NET|GROSS** key (For approval models, use **NET|B/G** key instead).
2. Select a sampling number, and put appropriate weight on platter, and press **UNIT** key. Display will show “- - - - -”. The scale will go into counting mode after weight is stable, and display will show the sample number.
 - ☐ Unit weight insufficient (**Pcs**): Sample unit weight is **less** than 0.2d or total sample weight is **less** than 20d (d=division)
 - ☐ While sampling, if there is insufficient sample or unit weight insufficient indication “▼”, the scale is still usable, but there may be slight inaccuracy.
 - ☐ After Power-off, the scale automatically memorizes the sampling number, and it is available when “Pcs” unit is selected next time.
 - ☐ If the setting is “automatic average unit weight “, if the object on platter > the previous sampling number more than 5 pcs, and also < less than 100% the previous sampling number, the scale will execute unit weight calibration automatically.

1-7 Error Messages

- E0** ⇒ The EEPROM is not working correctly.
The EEPROM is not set yet, or the circuit on PCB is broken.
- E1** ⇒ Zero is higher than the zero range when switching the indicator on.
- E2** ⇒ Zero is lower than the zero range when switching the indicator on.
- E4** ⇒ A/D value is unstable.
- OL** ⇒ The weight of the object is over 9 divisions of the maximum capacity.
- OL** ⇒ The weight of the object is under -1/6 maximum capacity.
- OF** ⇒ ADIC value is over the maximum range.



E10 ⇒ The scale is not in level status. (Only if level detector equipped)

Level Switch and E10 (option)

To use level switch, make J14 on PCB open circuited, display shows E10 and all keys stop working in the meantime. If J14 on PCB is short circuited, all functions work normally.

When level switch is used, and if is in level, a short circuited signal sends to CN6 and all functions work normally. If platform is tilted and not in level, an open circuited signal sends to CN6, and display shows E10 and all keys stop working.

1-8 Weight Units

kg	1 g = 0.001 kg	GN	1 g = 15.432358 GN
g	1 g = 1 g	dwt	1 g = 0.6430149 dwt
lb	1 g = 0.002204623 lb	ct	1 g = 5 ct
lb/oz	1 g = 0.03527396 oz	hk.tael	1 g = 0.02645546 Hk.catty
oz	1 g = 0.03527396 oz	viss	1kg = 0.612245 viss

1-9 Self-Test Mode

Turn off scale first. Hold [NET|GROSS] key (For approval models, use [NET|B/G] key instead), and press [ON|OFF] key to turn on scale. Wait till display shows 01 AdC to enter "Self-Test Mode".

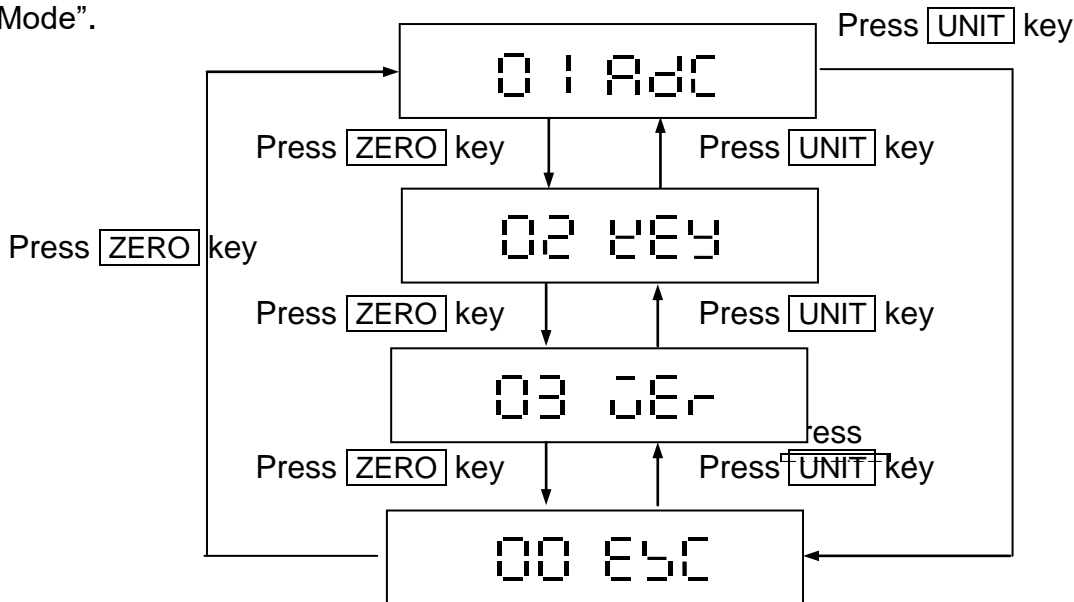

01 AdC INTERNAL VALUE MODE (must hook up full-bridge Load Cell to test)

- ① Press [TARE|PT] key to enter, and the display shows internal value
- ② Please check the internal value is within normal range is 0 ~ 400000 (no load)
- ③ Check whether the backlight is on
- ④ Press [ZERO] key to back to the last screen, the display shows 01 AdC

02 KEY KEYPAD TEST MODE

- ① Press [TARE|PT] key to enter, display shows KEY 05
Keypad's internal code: [TARE|PT] key = 06, [UNIT] key = 05,
[NET|B/G] or [NET|GROSS] key = 04, [M+|PRINT] key = 03, [F] key = 02
- ② Press [ZERO] key to back to the last screen, the display shows 02 KEY



03 0Er FIRMWARE VERSION DISPLAY MODE

- ① Press TARE|PT key to display firmware version 02005
- ② Press TARE|PT key again to display maintenance number 60X (X is ranged from 0~9) for 2 seconds
- ③ Press ZERO key to back to the last screen, display shows 03 0Er

00 Esc BACK TO THE LAST SCREEN

Press TARE|PT key to exit self-test mode, the scale will re-power on automatically.



Chapter 2 Configurations

In the weighing mode, press **NET|GROSS** key (For approval models, use **NET|B/G** key instead) and **ZERO** keys at the same time to enter the configuration mode. The LCD shows 01 FnC.

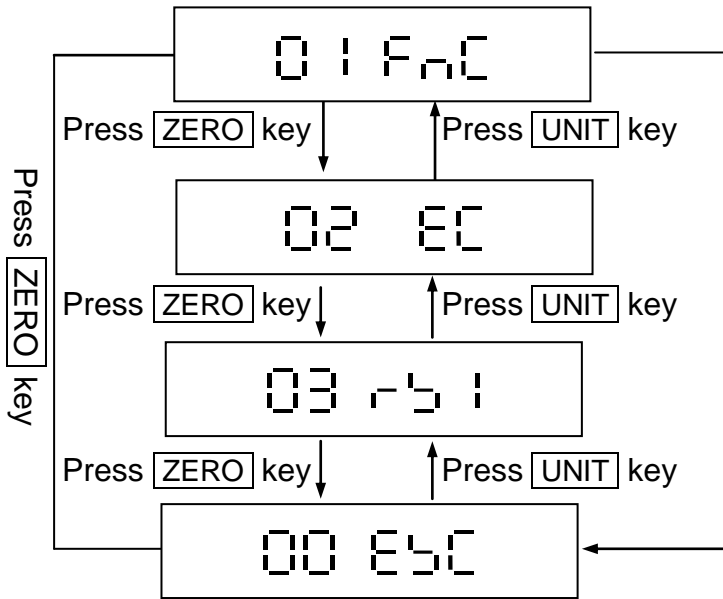

01 FnC ⇒ General Function Setting
 02 EC ⇒ External Weight Calibration
 03 rS1 ⇒ RS232 Bi-direction Function Setting
 00 ESC ⇒ Exit

Refer to the following sections for the detailed of each setting.

2-1 01 FnC General Function Setting

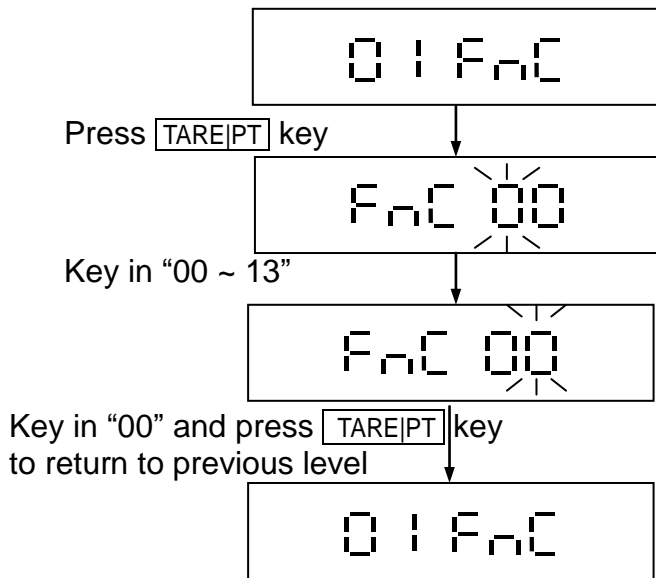

ZERO key ⇒ Upward key (0~9 digit entry)
UNIT key ⇒ Downward key (0~9 digit entry)
TARE|PT key ⇒ Move cursor rightward
NET|GROSS key ⇒ Move cursor leftward
 (For approval models, use **NET|B/G** key instead)

FnC 00 ⇒ Return to to previous level
 FnC 01 ⇒ Automatic Backlight
 FnC 02 ⇒ Automatic Power-off Timer Settings
 FnC 03 ⇒ Hi/Lo/OK Settings
 FnC 04 ⇒ Restore the Default Settings
 FnC 05 ⇒ Noise Filter Settings
 FnC 06 ⇒ Hold Function Settings
 FnC 07 ⇒ Auto Unit Weight Averaging Setting
 FnC 08 ⇒ Reserved
 FnC 09 ⇒ Reserved
 FnC 10 ⇒ Record Last Zero
 FnC 11 ⇒ Foot switch on/off settings (Option)
 FnC 12 ⇒ **F** key function settings
 FnC 13 ⇒ Zero Setting
 FnC 14 ⇒ Backlight Color Setting
 FnC 15 ⇒ Backlight Brightness Setting



2-1-1 FnC 01 Auto Backlight

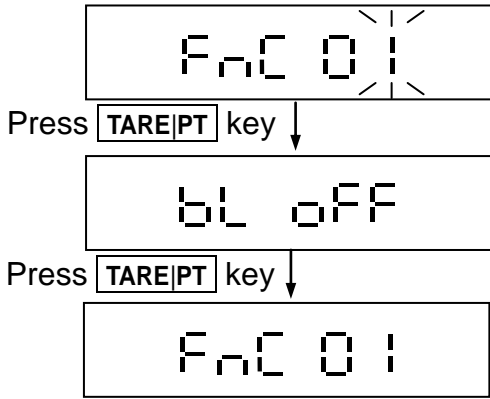

Display the last used value
 ➤ Default setting = OFF
 Use **ZERO** or **UNIT** key to select
 on → backlight on
 Auto → automatic backlight
 OFF → backlight off

Auto backlight function

When weight > 10d or any key is pressed, backlight is turned on. When weight < 10d or no key is pressed for 10 seconds, backlight is switched off.

2-1-2 FnC 02 Auto Power-off Timer Setting

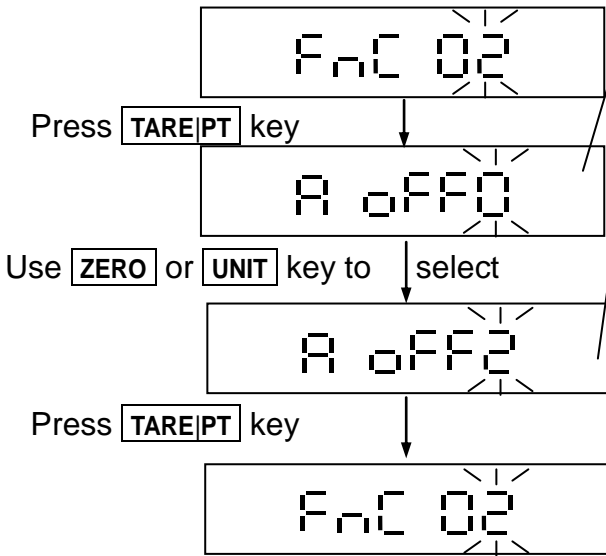

Display the last used value
 Default setting = 0 (No auto power-off)

Automatic power-off timer setting

Use **ZERO** or **UNIT** key to select
 0 ⇒ No auto power-off
 1 ⇒ Switch scale off if idle for 1 minute
 2 ⇒ Switch scale off if idle for 2 minute
 ⋮
 9 ⇒ Switch scale off if idle for 9 minute

Auto power-off

When weight < 10d, and scale is idle longer than selected duration, the scale automatically switches off.

2-1-3 FnC 03 HI/LO/OK Settings

☰ When the high limit and low limit are both set as "0", the Hi/Lo/OK function is disabled.

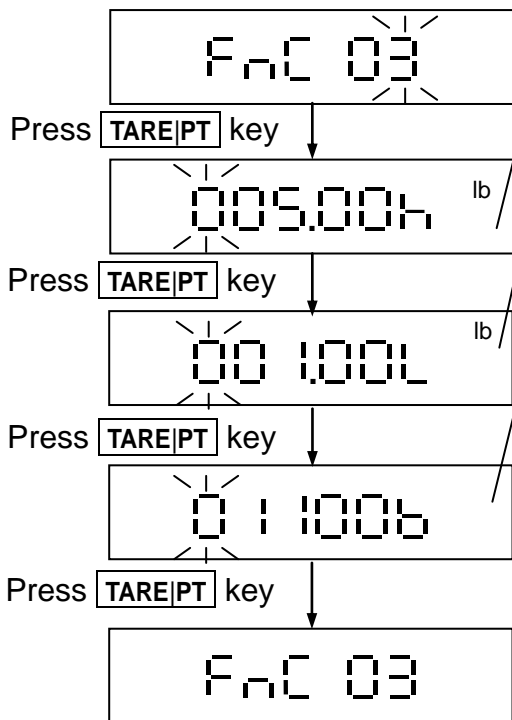

Display the last used value
 Enter the high limit value and Press **TARE|PT** key

Display the last used value
 Enter the low limit value and Press **TARE|PT** key

Display the last used value

Alarm setting

00000b
 (a)(b)(c)

The definition of a, b, c positions:

- (a) ⇒ 1 = alarm on
0 = alarm off
- (b) ⇒ 1 = alarm when stable
0 = alarm even when unstable
- (c) ⇒ 1 = alarm when weight is between high and low limits
0 = alarm when weight > high limit or when 10d < weight < low limit



If backlight is on, yellow backlight is for Low value, green backlight for OK value, and red backlight for High value.

2-1-4 FnC 04 Restore to the Default Settings

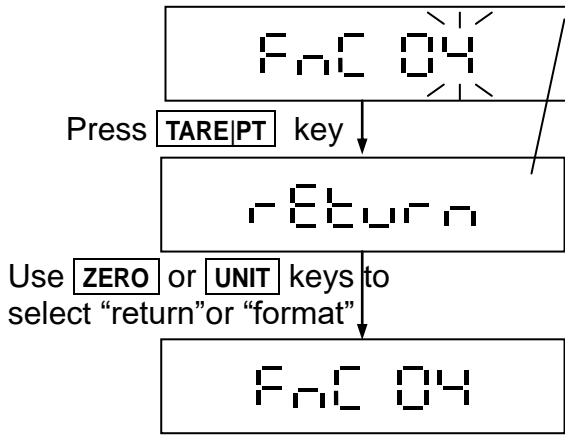

Use **ZERO** or **UNIT** keys to select "rEtur n" or "ForMat"

rEtur n ⇒ Return (Cancel the restoration)

ForMat ⇒ Restore to default setting

The following settings will be restored to their default values:

- 1) External weight calibration
- 2) HI/LO/OK setting values
- 3) Noise filter setting (External)
- 4) Sampling settings for the counting function

Approval model has no access to FnC 04

2-1-5 FnC 05 Noise Filter Settings

When modifying FnC 05, the parameters of CFn 01 remain un-altered.

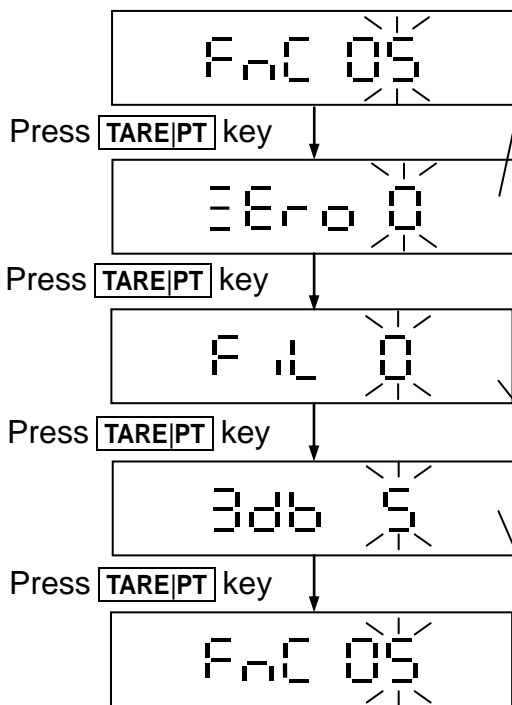

Zero display setting

Display the last used value.

Use **ZERO** or **UNIT** key to select 0~9. Default = 0.

Activate when weight is over 1/3 max and when object is removed and display is approaching 0. When approaching within 0 ± selected value, weight display 0.

- | | | |
|----------|----------|----------|
| 0 ⇒ 0 | 4 ⇒ ± 4d | 7 ⇒ ± 7d |
| 1 ⇒ ± 1d | 5 ⇒ ± 5d | 8 ⇒ ± 8d |
| 2 ⇒ ± 2d | 6 ⇒ ± 6d | 9 ⇒ ± 9d |
| 3 ⇒ ± 3d | | |

Digital switch & Stabilization range setting

Display the last used value.

Use **ZERO** or **UNIT** keys to select 0~9. Default = 0

The larger value: become stable more quickly.

Filter parameter setting

Display the last used value.

Use **ZERO** or **UNIT** keys to select 0 ~ 9. Default = 5.

The larger value: faster response; therefore, more unstable. If set to 9, AD value is not filtered.

Input AD value = Output AD value

Approval model has no access to FnC 05

- ... **ZERO** key ⇒ Upward key (0~9 digit entry)
- ... **UNIT** key ⇒ Downward key (0~9 digit entry)
- ... **TARE|PT** key ⇒ Move cursor rightward
- ... **NET|GROSS** key ⇒ Move cursor leftward
- ... (For approval models, use **NET|B/G** key instead)



2-1-6 FnC 06 Hold Function Settings

When CFn 02 =1 (OIML or NTEP approval), FnC 06 is fixed to hold=0 and cannot be changed

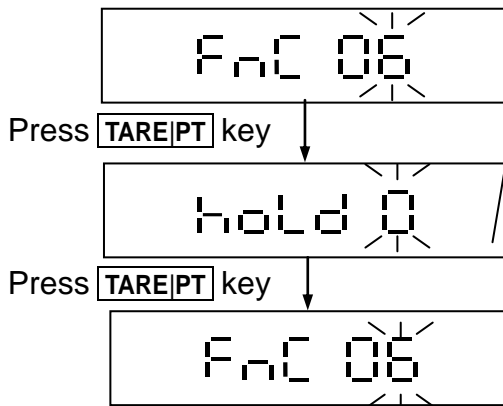

Hold function setting

Display the last used value

Use ZERO or UNIT keys to select 0~5

- Default setting = 0
- 0 ⇒ Hold function disabled
- 1 ⇒ “Peak hold” mode
- 2 ⇒ “Stable hold 1” mode
- 3 ⇒ “Stable hold 2” mode
- 4 ⇒ “Animal scale hold 1” mode
- 5 ⇒ “Animal scale hold 2” mode

hoLd 0 = Hold is disabled

hoLd 1 = “Peak hold” mode: Hold peak weight on the display until a key is pressed to release hold and get a new peak weight.

hoLd 2 = “Stable hold 1” mode: When the weight is stable, Hold the current stable weight until a key is pressed to release hold and get a new stable weight.

hoLd 3 = “Stable hold 2” mode: When the weight is stable, Hold the current stable weight until weight returns to zero (<10d), the hold is cancelled automatically.

hoLd 4 = “Animal scale hold 1” mode

When no load, display “- - - - -”. After the animal is on the platter and the weight is stable, the display Hold the current stable weight value. When the animal is off the platter, the display “- - - - -” and the hold is released. If the weight is hardly stable, display Hold the average weight in 10 seconds until the weight < 10e and display shows “- - - - -” or press any key to calculate a new weight.

hoLd 5 = “Animal scale hold 2” mode

When no load, display “0.000”. After the animal is on the platter and the weight is stable, display Hold the current stable weight value. When the weight added or removed on the platter is > the hold range set in hold 5, hold is released and calculate a new hold weight. If the weight is hardly stable, display Hold the average weight in 10 seconds. ZERO and TARE|PT keys are inactive here. Hold lock speed can be set through SPEEd setting. “1” is the fastest and “5” is the slowest.



Animal scale hold 1 hold 4

Press **TARE|PT** key

hold 4

Hold function setting

Display the last used value

Use **ZERO** or **UNIT** key to select 4.

Press **TARE|PT** key to enter the hold setting

Press **TARE|PT** key

0 10%

Allowed tolerance range

Use **ZERO** or **UNIT** keys to enter value (1%~100%)

Default setting = 10%

Press **TARE|PT** key

8

Number of counts for averaging

Use **ZERO** or **UNIT** keys enter value (1,2,4,8,16,32,64)

Default setting = 8

Press **TARE|PT** key

Fnc 06

Animal scale hold 2 hold 5

Press **TARE|PT** key

hold 5

Hold function setting

Display the last used value

Use **ZERO** or **UNIT** key to select 5.

Press **TARE|PT** key to enter the hold setting

Press **TARE|PT** key

SPEED 1

Hold speed setting

Display the last used value

Use **ZERO** or **UNIT** keys to enter value (1~5)

1: fastest; 5: slowest

Press **TARE|PT** key

30.00 kg

Hold range setting

Display the last used value

Use **ZERO** or **UNIT** keys to enter value (0 ~ max capacity)

Press **TARE|PT** key

Fnc 06

ZERO key ⇒ Upward key (0~9 digit entry)

UNIT key ⇒ Downward key (0~9 digit entry)

TARE|PT key ⇒ Move cursor rightward

NET|GROSS key ⇒ Move cursor leftward

(For approval models, use **NET|B/G** key instead)

- When weight returns to zero, Hold is released
- After weight is HOLD, Hold is released only when weight change is more than \pm Hold range. For example: if Hold range = 1 kg. Weight is held at 8.5kg after buzzer sounds. When weight changes outside the range of 8.5 ± 1 kg, for example, when weight is > 9.5 kg or < 7.5 kg, HOLD is released and until new HOLD weight is re-captured (displays weight changes until it enters HOLD).
- Repeat to test the same animal for more than 10 times to compare the errors. Then finalize the Hold speed and Hold range setting.



2-1-7 FnC 07 Auto Unit Weight Averaging Setting

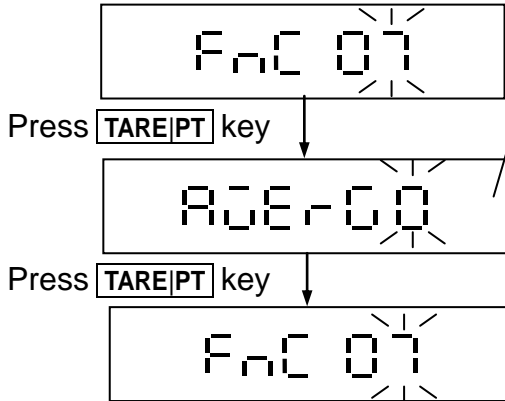

Auto unit weight averaging setting

Display the last used value

Use ZERO or UNIT key to select 0~1.

➤ Default setting = 0

0 ⇒ Enable Auto unit weight averaging

1 ⇒ Disable auto unit weight averaging

ZERO key ⇒ Upward key (0~9 digit entry)

UNIT key ⇒ Downward key (0~9 digit entry)

TARE|PT key ⇒ Move cursor rightward

NET|GROSS key ⇒ Move cursor leftward

(For approval models, use NET|B/G key instead)

2-1-8 FnC 10 Record Last Zero

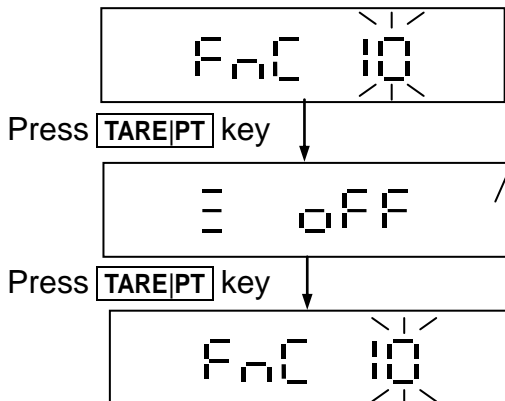

Record Last Zero

Display the last used value

Use ZERO or UNIT key to select on or OFF.

➤ Default setting = OFF

on ⇒ Enable Record the last zero

OFF ⇒ Disable Record the last zero

☰ FnC 10 is only for non-approval where CFn 02 = 0

2-1-9 FnC 11 Foot Switch Settings (Option)

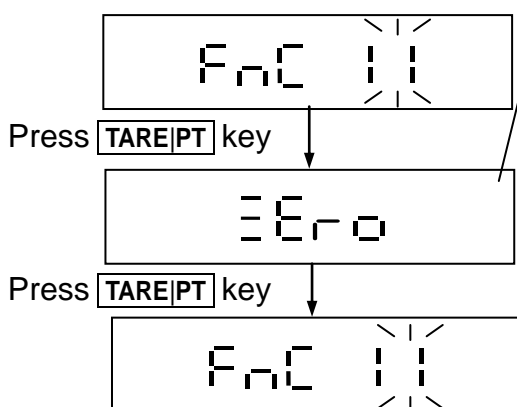

Foot switch function

Display the last used value

Use ZERO or UNIT key to select Foot switch as ZERo, tArE, or Print key.

ZERo ⇒ as 1ZERO key

tArE ⇒ as 1TARE key

Print ⇒ as PRINT key, use to send data through RS232

1) When rS1 03 = 10 or 11, after printing final total summary, it will clear totalization data.

2) When set to Brazil (CFn02=4) and rS1 04 = r_F_L_u_b, print rS1 03 format with totalization function.



2-1-10 FnC 12 F Key Function Settings

(For approval models, use key instead)

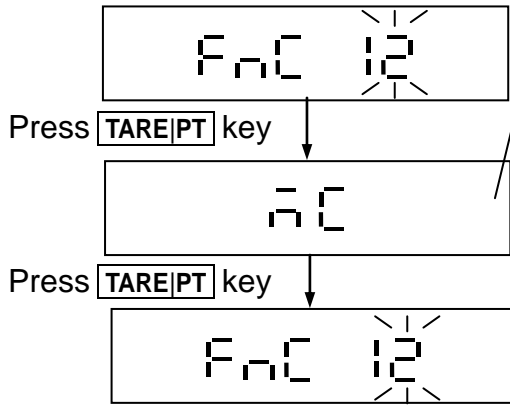

Foot switch function

Display the last used value

Use **ZERO** or **UNIT** key to select **F** key as MC, hr or t-tP.

MC ⇒ as **MC** key: Press **MC** when weight returns to 0 to clear all totalization data

hr ⇒ as **HR** key: Press **HR** to switch to high resolution display for 5 seconds.

t-tP ⇒ select “t-tP” to display tare weight or Pre-tare weight for 2 seconds, and then returns to net weight. If both tare and Pre-tare weight exist, display tare weight first and then Pre-tare weight.

2-1-11 FnC 13 Zero Key Setting

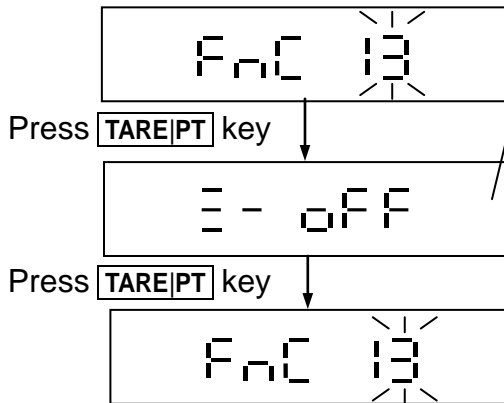

Unrestricted zero key range setting

Display the last used value

Use **ZERO** or **UNIT** key to select on or oFF.

➤ Default setting = oFF

on ⇒ Enable, zero for any weight

oFF ⇒ Disable

FnC 13 is only for non-approval where CFn 02 = 0

2-1-12 FnC 14 Backlight Color Setting

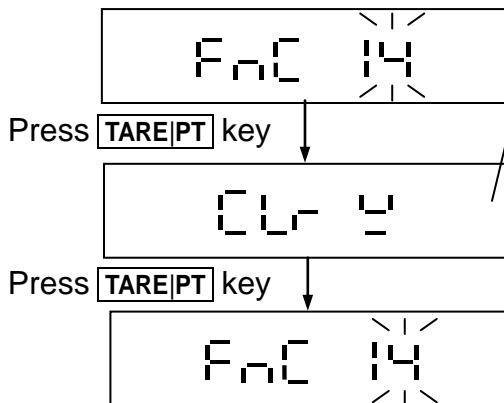

Backlight color setting

Display the last used value

Use **ZERO** or **UNIT** key to select W, r G, y for backlight.

⇒ W for white ⇒ r for red

⇒ G for green ⇒ y for yellow

2-1-13 FnC 15 Backlight Brightness Setting

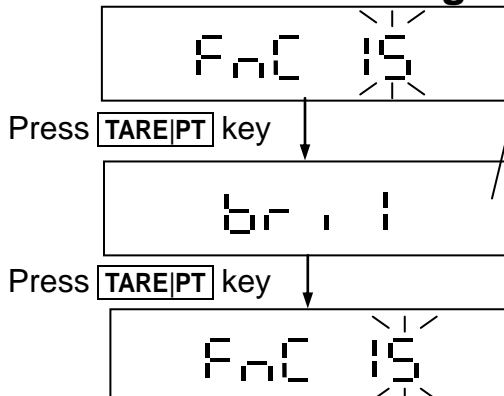

Backlight brightness setting

Display the last used value

Use **ZERO** or **UNIT** key to select 1~4.

1: dimmest 4: brightness



2-2 02 EC External Weight Calibration

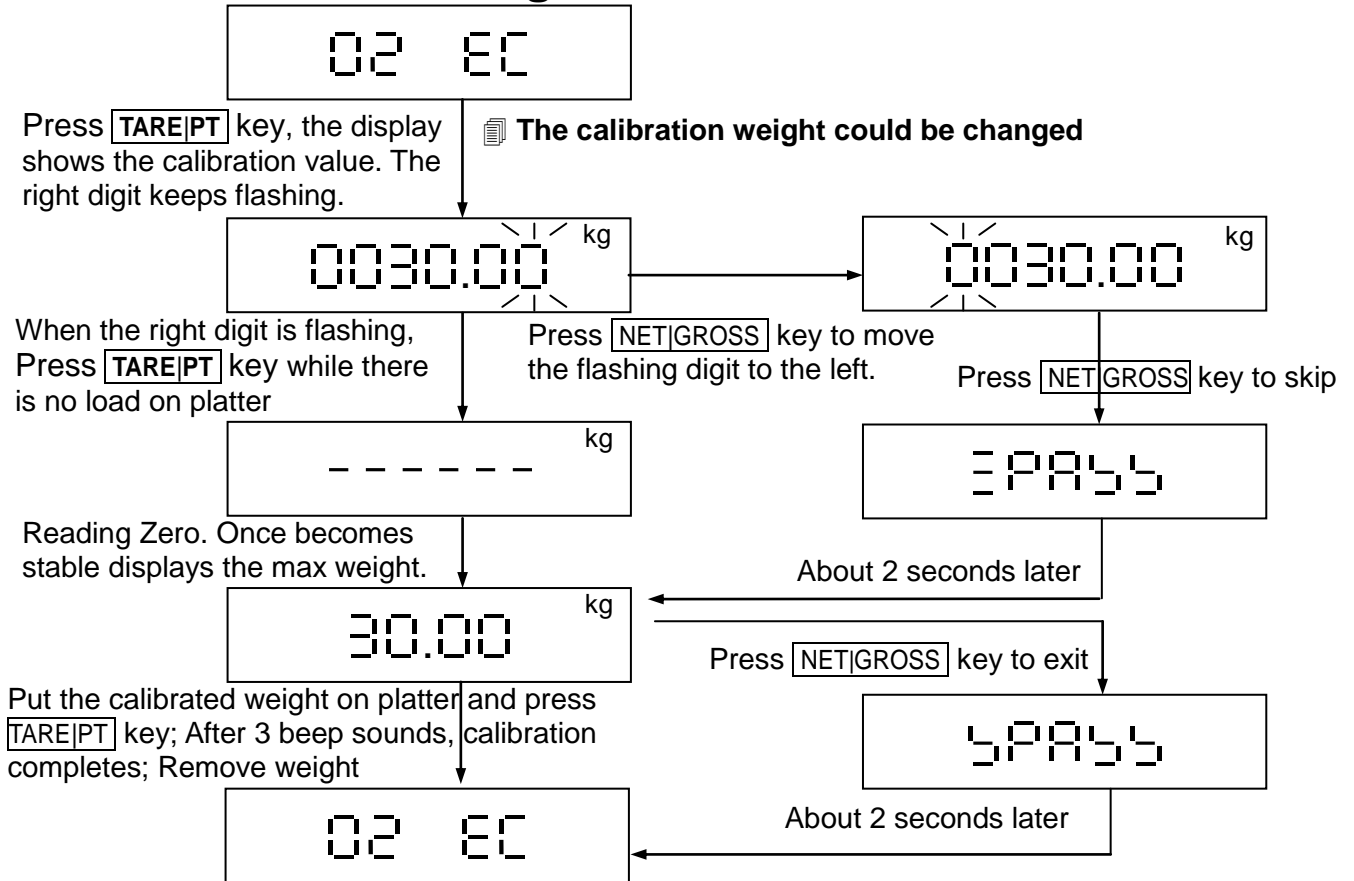

02 EC is only for non-approval models

The conditions for external weight calibration:

The calibrated weight > 100e, and the must be within $\pm 10\%$ of factory's calibrated weight.



2-3 03 rS1 RS232 Serial Interface Settings

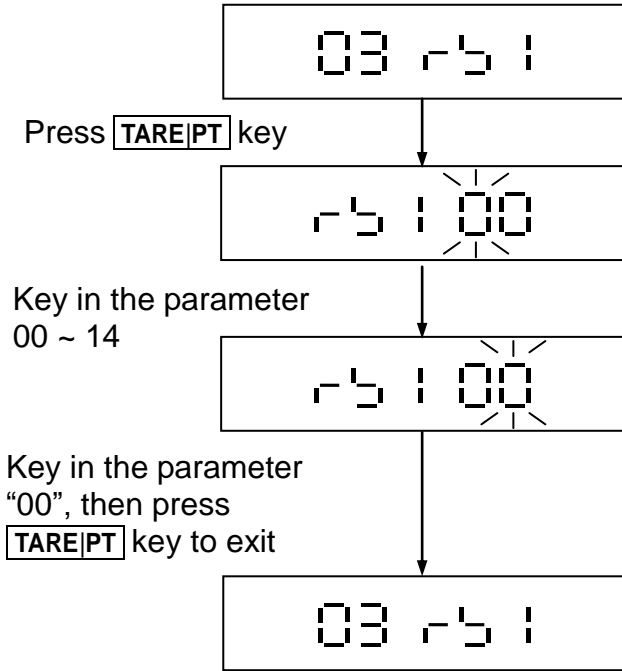

- rS1 00 ⇒ Return to to previous level
- rS1 01 ⇒ Baud Rate Settings
- rS1 02 ⇒ Communication Protocol Settings
- rS1 03 ⇒ Output Format Settings
- rS1 04 ⇒ Transmission Method
- rS1 05 ⇒ Continuous Transmission Rate
- rS1 06 ⇒ Auto Transmission at Zero
- rS1 07 ⇒ Reset of Auto Transmission
- rS1 08 ⇒ Output Condition Settings
- rS1 09 ⇒ RS232 6/7 Digits Setting
- rS1 10 ⇒ RTC Adjustment
- rS1 11 ⇒ Y/M/D Print Format Selection
- rS1 12 ⇒ RS485 ID Input (Option)
- rS1 13 ⇒ Line Feed Input

2-3-1 rS1 01 Baud Rate Settings

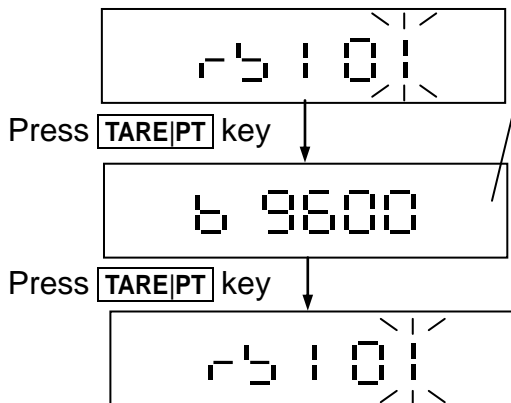

Baud rate setting

Display the last used value

Use **ZERO** or **UNIT** key to select the desired Baud rate
600 · 1200 · 2400 · 4800 · 9600 · 19200 (bits/sec)

Default setting = 9600 (bits/sec)

☒ If Bluetooth is used, set to 9600 and “n 8 1” protocol

2-3-2 rS1 02 Communication Protocol Settings

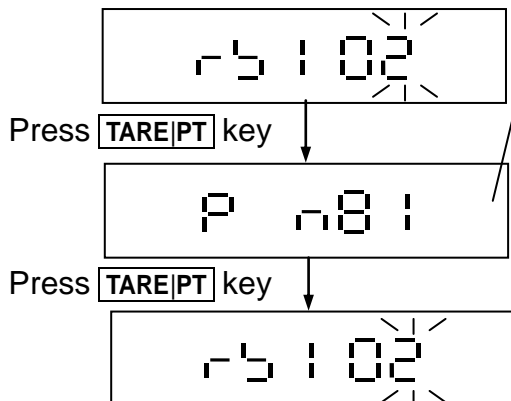

Communication protocol setting

Display the last used value

Use **ZERO** or **UNIT** key to select n 8 1, E 7 1, O 7 1.

Default setting = n 8 1

☒ If Bluetooth is used, set to 9600 and “n 8 1” protocol

ZERO key ⇒ Upward key (0~9 digit entry)

UNIT key ⇒ Downward key (0~9 digit entry)

TARE|PT key ⇒ Move cursor rightward

NET|GROSS key ⇒ Move cursor leftward

(For approval models, use **NET|B/G** key instead)



2-3-3 rS1 03 Output Format Settings

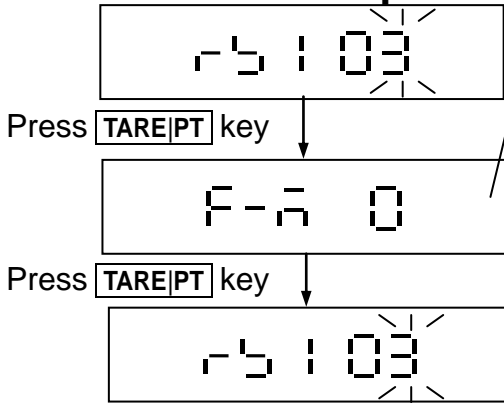

Communication protocol setting

Display the last used value

Use **ZERO** or **UNIT** key to select 0~20. Default = 0

0 ⇒ Synchronize with display

1 ⇒ Gross weight

2 ⇒ Net weight

3 ⇒ Synchronized in simple format

4 ⇒ Synchronized Gross weight in simple format

5 ⇒ Synchronized Net weight in simple format

6 ⇒ Hi/Lo/OK status + synchronized in simple format

7 ⇒ Hi/Lo/OK status + synchronized Gross weight in simple format

8 ⇒ Hi/Lo/OK status + synchronized Net weight in Simple format

9 ⇒ Tare weight

14 ⇒ Brazil printing format note 5

10 ⇒ **M+** Transmission 1 note 1

15 ⇒ Reserved

11 ⇒ **M+** Transmission 2 note 2

16 ⇒ Reserved

12 ⇒ Brazil printing format note 3

17 ⇒ KPZ printing format note 6

13 ⇒ Brazil printing format note 4

Format 10.11 are not available on counting mode

Format 12.13.14 are only for Brazil

Note1: F - r̄ | : = **M+** Transmission 1

Ticket No.

Date year/month/day & day/month/year (choose 1 out of 2 date formats)

Time

G

T (PT when only pre-tare, T when tare or both tare and pre-tare)

N

Total Net (This line will only print when data is erased, showing net weight total of every count)

When rS1 13 = 2 (default), 3 blank lines are inserted between data. After memory is cleared, a summary report of total records and weights will be printed and then insert 4 blank lines afterward.

To add company name, use F-M 18 format and set company name in rS1 14 (see note 7).

Note2: F - r̄ | : = **M+** Transmission 2

Ticket No.

Date year/month/day & day/month/year (choose 1 out of 2 date formats)

Time

G

T (PT when only pre-tare, T when tare or both tare and pre-tare)

N

Total Weight (This line will only print when data is erased, showing gross weight total of every count)

When rS1 13 = 2 (default), 3 blank lines are inserted between data. After memory is cleared, a summary report of total records and weights will be printed and then insert 4 blank lines afterward.



Note3: F - r̄ ī = Brazil printing format

If it is not Brazil version, it can only print under continuous transmission.

If it is Brazil version, under decimal units mode, FnC 11 = Print and rS1 04 = r̄_ī F̄ L̄ Ū B̄, it can print out. It is not available on counting mode.

For example:

70.15Kg print as: =51.07000=51.07000=51.07000=51.07000=51.07000

negative 70.15Kg print as: =51.0700=-51.0700=-51.0700=-51.0700=-51.0700-

Note4: F - r̄ ī = Brazil printing format

If it is not Brazil version, it can print under key transmission, auto transmission and order mode.

If it is Brazil version, when the scale is stable and under decimal units mode,

FnC 11 = Print and rS1 04 = r̄_ī F̄ L̄ Ū B̄, it can print out.. It is not available on counting mode.

Transmission format as followed:

F	R	"	I	R	W	T	3	0	0	0	"	<LF>														
?	<LF>																									
G	G	G	,	G	G	G	<LF>																			
T	T	T	,	T	T	T	<LF>																			
N	N	N	,	N	N	N	<LF>																			
A	A	A	,	A	A	A	<LF>																			
C	C	C	C	C	C	<LF>																				
D	D	/	M	M	/	Y	Y	<LF>																		
H	H	:	m	m	:	S	S	<LF>																		
n	n	n	,	n	n	n	t	t	t	,	t	t	a	a	a	,	a	a	a	c	c	c	c	c	c	<LF>
P	1	,	1	<LF>																						

G = gross weight

T,t = tare

N,n = net weight

A,a = accumulating weight

C,c =accumulating times

D = date (DD/MM/YY) DD: day MM: month YY: year

H = time(HH:mm:ss) HH: hour mm: minute SS: second

For example:

tare 0.2kg, net weight 1key, press **M+**

FR"IRWT3000"

?

1,200

0,200

1,000

1,000

1

30/05/00

00:54:12

001,000000,200001,000000001

P1,1

Note5: F - r̄ ī = Brazil printing format

If it is not Brazil version, it only can print under continuous transmission.

If it is Brazil version, under decimal units mode, FnC 11 = Print and rS1 04 = r̄_ī F̄ L̄ Ū B̄, it can print out. It is not available on counting mode.

Transmission format as followed:

S,GGG .GGG ,TTT .TTT,NNN.NNN

S = 0:stable 1: unstable

G = gross weight



T = tare + pre-tare

N = net weight

For example:

tare 1 kg, net weight 0.2kg, gross weight 1.2 kg , stable, then show as followed:
0,001.200,001.000,000.200

Take off the weight then show as followed:

0,000.000,001.000,-01.000

Note6: F - r̄ : 1 = KPZ printing format

Press **[M+]**, show the following format

F	R	"	W	T	3	N	"	<LF>											
?	<LF>																		
G	G	,	G	G	G	<LF>													
T	T	,	T	T	T	<LF>													
PT	PT	,	PT	PT	PT	<LF>													
N	N	,	N	N	N	<LF>													
pcs	pcs	pcs	pcs	pcs	pcs	<LF>													
N	N	N	N	N	N	T	T	T	T	T	T	pcs	pcs	pcs	pcs	pcs	pcs	<LF>	
p	1	,	1	<LF>															

G=gross weight, T=tare weight, PT=pre-tare weight, N=net weight, pcs=pieces (without decimal point)

Example:
PT 0.3 kg
T 0.7kg
G 1.2kg
N 0.2kg
Pcs 20

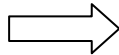

FR"WT3N"
?
1,200
0,700
0,300
0,200
20
000200000700000020
p1,1

Press **[MC]**, show the following format

F	R	"	5	2	0	T	"	<LF>											
?	<LF>																		
R	R	,	R	R	R	<LF>													
N	N	,	N	N	N	<LF>													
pcs	pcs	,	pcs	pcs	pcs	<LF>													
R	R	R	R	R	R	N	N	N	N	N	N	pcs	pcs	pcs	pcs	pcs	pcs	<LF>	
p	1	,	1	<LF>															

R=total number of totalized records, N=total net weight, pcs=total pieces (without decimal point)

FR"WT3N"
?
1
0,200
20
000001000200000020
p1,1



2-3-4 rS1 04 Transmission Method

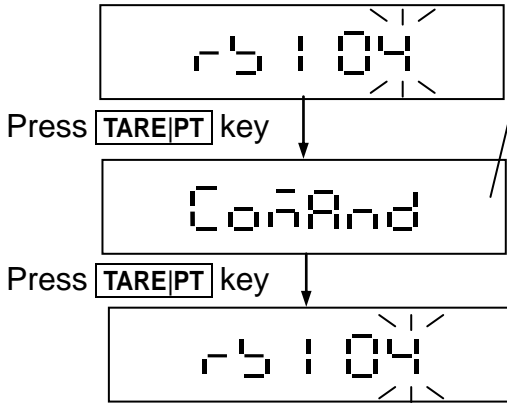

Transmission Method

Display the last used value

Use **ZERO** or **UNIT** key to select. Default = **ConAnd**

ConAnd = Command mode

StrEAñ = Continuous transmission

Auto = Auto transmit when stable

rS-off = RS232 is off

ñPlus = M+ Mode

2-3-5 rS1 05 Continuous Transmission Rate

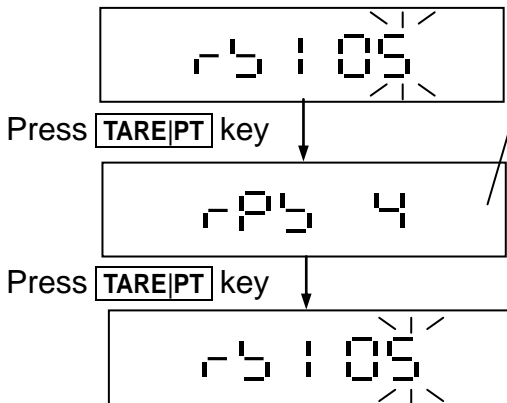

Continuous transmission rate setting

Display the last used value

Use **ZERO** or **UNIT** key to select 1, 2, 4, 8, 16 or Max (times/sec). Default = 4

ZERO key ⇒ Upward key (0~9 digit entry)

UNIT key ⇒ Downward key (0~9 digit entry)

TARE|PT key ⇒ Move cursor rightward

NET|GROSS key ⇒ Move cursor leftward

(For approval models, use **NET|B/G** key instead)

2-3-6 rS1 06 Zero Band Setting for Auto Transmission

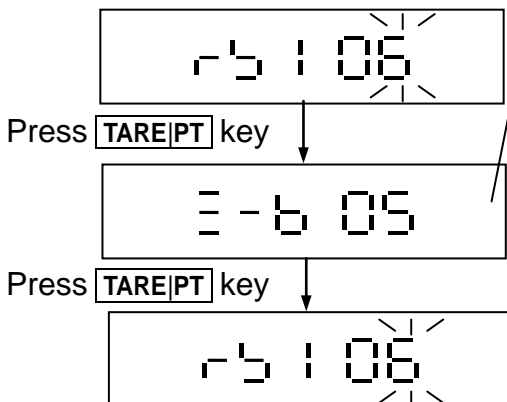

Zero Band Setting for Auto Transmission

Display the last used value

To auto transmit once, weight must return < zero band first, and then place weight >= zero band.

Use **ZERO** or **UNIT** key to select 00~99 d (d=increment) for zero band. Default = 05.

To auto transmit once, weight must return < zero band first, and then place weight >= zero band.

☞ If rS1 06 set to 00, when the scale is at zero and keeping stable, the data are keeping transmitted as “Continuous Transmission”.



2-3-7 rS1 07 Weight Band Setting for Auto Transmission

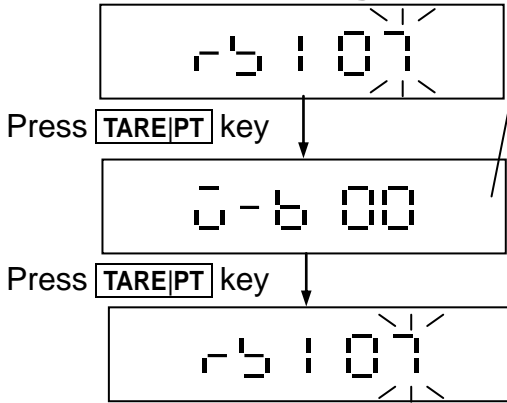

Weight Band Setting for Auto Transmission

Display the last used value
 rs1 07 must be used with rs1 06. After data has been sent once and weight is not removed, to send data again, please keep adding weight until: weight is > zero band (rS1 06)+ weight band (rS1 07)

Use **ZERO** or **UNIT** key to select 00~99 d (d=increment) for weight band. Default = 00.

☞ If rS1 07 set to 00, when the scale is at zero and keeping stable, the data are keeping transmitted as “Continuous Transmission”.

2-3-8 rS1 08 Output Condition Settings

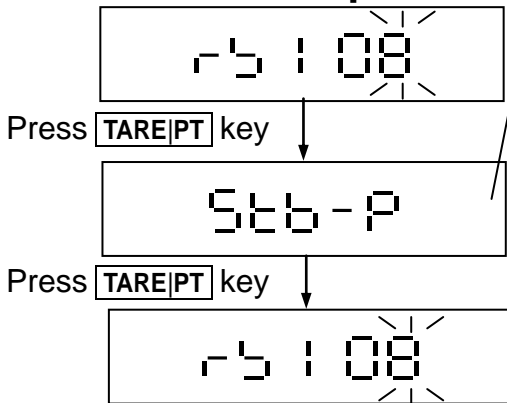

Output condition settings

Display the last used value
 Use **ZERO** or **UNIT** key to select. Default = Stb-P.
 ALL-P = Output always
 Stb-P = Output when stable (No output when OL or unstable)
 StOL-P = Output when stable (OL included)

- ZERO** key ⇒ Upward key (0~9 digit entry)
- UNIT** key ⇒ Downward key (0~9 digit entry)
- TARE|PT** key ⇒ Move cursor rightward
- NET|GROSS** key ⇒ Move cursor leftward
- (For approval models, use **NET|B/G** key instead)

2-3-9 rS1 09 RS232 6/7 Digits Setting

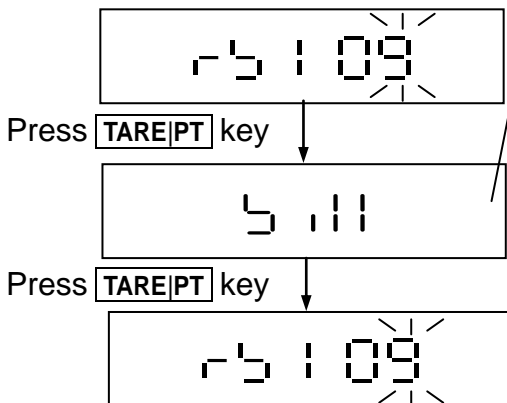

Output condition settings

Display the last used value
 Use **ZERO** or **UNIT** key to select. Default = 5 11.
 5 11 = 6 digits
 5E0E1 = 7 digits



2-3-10 rS1 10 RTC Adjustment

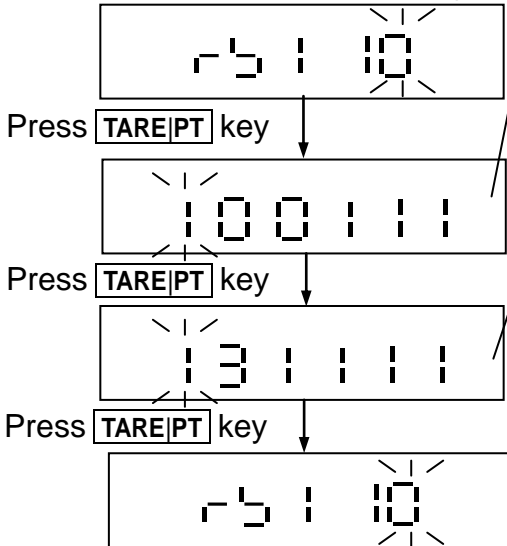

Enter date in YY/MM/DD

Display the last used value

Use **ZERO** or **UNIT** key to select and use **TARE|PT** key to confirm and move cursor to the right. When cursor move to the rightmost end and press **TARE|PT** key to save.

Enter time in HH/MM/SS

Display the last used value

Use **ZERO** or **UNIT** key to select and use **TARE|PT** key to confirm and move cursor to the right. When cursor move to the rightmost end and press **TARE|PT** key to save. RTC adjustment is complete

2-3-11 rS1 11 Y/M/D Print Format

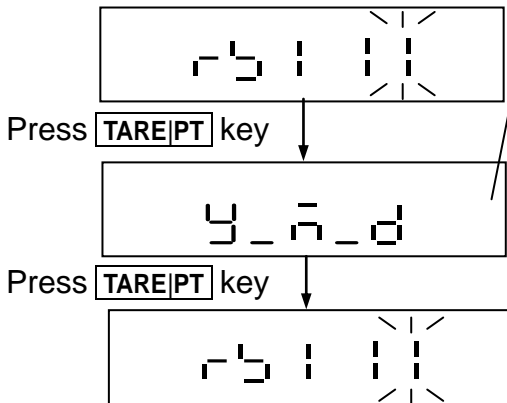

Y/M/D Print Format

Display the last used value

Use **ZERO** or **UNIT** key to select.

Y_M_d: print as Year/Month/Day

d_M_Y: print as Day/Month/Year

- ZERO** key ⇒ Upward key (0~9 digit entry)
- UNIT** key ⇒ Downward key (0~9 digit entry)
- TARE|PT** key ⇒ Move cursor rightward
- NET|GROSS** key ⇒ Move cursor leftward
- (For approval models, use **NET|B/G** key instead)

2-3-12 rS1 12 RS485 ID Input (Option)

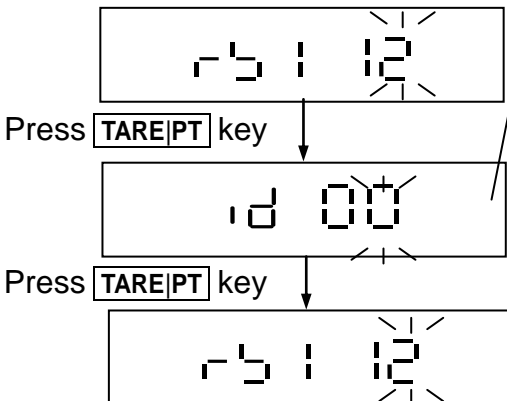

RS485 ID Input

Display the last used value

Use **ZERO** or **UNIT** key to select

2-3-13 rS1 13 Numbers of Line Feed for rS1 03 = 10 or 11

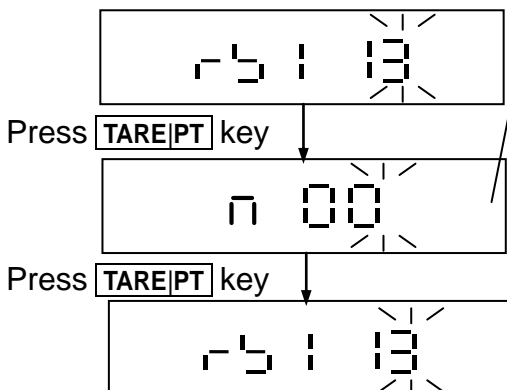

Numbers of Line Feed for rs1 03 = 10 or 11

Display the last used value

Use **ZERO** or **UNIT** key to select. Default = 2.

☞ When rS1 03 = 2, 3 blank lines are inserted between data. After memory is cleared, a summary report of total records and weights will be printed and then insert 4 blank lines afterward.



Appendix 1 ASCII Code Table

	0	1	2	3	4	5	6	7	8	9	
ASCII	30H	31H	32H	33H	34H	35H	36H	37H	38H	39H	
	A	B	C	D	E	F	G	H	I	J	K
ASCII	41H	42H	43H	44H	45H	46H	47H	48H	49H	4AH	4BH
	L	M	N	O	P	Q	R	S	T	U	V
ASCII	4CH	4DH	4EH	4FH	50H	51H	52H	53H	54H	55H	56H
	W	X	Y	Z	a	b	c	d	e	f	g
ASCII	57H	58H	59H	5AH	61H	62H	63H	64H	65H	66H	67H
	h	i	j	k	l	m	n	o	p	q	r
ASCII	68H	69H	6AH	6BH	6CH	6DH	6EH	6FH	70H	71H	72H
	s	t	u	v	w	x	y	z			↵
ASCII	73H	74H	75H	76H	77H	78H	79H	7AH			0DH

Appendix 2 7-Segment Display Characters

0	1	2	3	4	5	6	7	8	9
A	B	C	D	E	F	G	H	I	J
K	L	M	N	O	P	Q	R	S	T
U	V	W	X	Y	Z				



Appendix 3 RS-232 Data Format

☒ Command Mode

On RS485 command mode, the format is as following,

1. If RS485's ID setting is 0(RS1 12), and the command is the same as regular RS232.
2. A. If RS485's ID setting is not 0(assume 99), "@ID" has to be added in front of every command. If you wish to command a zero-return, the complete command is @99MZY, then press "ENTER" key
 B. If there is an error on entered command, letter "E" will show up + "Unidentified Command"
e.g. @99MZZ
 The response message is => 99E1MZZ
3. RS485 responses only to machines of identified ID code

Command Format A

Host	Command
Slave	Command

MZ	Zero	SO	Command mode
MT	Tare	UA	Switch to the first unit
MG	Gross weight	UB	Switch to the second unit
MN	Net weight	UC	Switch to the third unit
CT	Clear TARE value	UD	Switch to the forth unit
SC	Continuous transmission	UE	Switch to the fifth unit
SA	Auto transmission	UF	Switch to the sixth unit
%	Stop continuous transmission and enter the command mode		

Note: UA ~ UF settings are depended on the model of the scale

If continuous "SC" or automatic "SA" transmission is used, to change back command mode, please input "%" and press the enter key before sending the next data.

Note: rs1 05 can modify the number data per second.

Command Format B

Host	Command
Slave	Data

RW	Read current weight	RH	Read Gross (simple)
RG	Read Gross weight	RI	Read Net (simple)
RN	Read Net weight	RJ	Read comparison situation + current display of weight (simple)
RT	Read TARE	RK	Read comparison situation + Gross (simple)
RB	Read current display of weight (simple)	RL	Read comparison situation + Net (simple)
RZ	Print F-M 13 Brazil format		

- Note:**
- a. add % before the command to read continuously
 - b. add # before the command to transmit a stable value



RJ,RK,RL Command Description

If RL command entered, and

if weight is higher than HI (FNC 03 setting), and if the current weight is 10 kg, the following will be displayed: "100+ 10.000"

If weight is higher than HI (FNC 03 setting), and if the current weight is 0.5 kg, the following will be displayed: "001+ 0.500"

If weight is between HI and LOW, and if the current weight is 1 kg, the following will be displayed: 010+ 1.000

Read weight comparison setting value RS○○□□

○○: Groups(00 ~ 09) □□: Setting Items

HI	Show "HI" presetting value
LO	Show "LO" presetting value

Note : ○○(Group) is various depended on different models

- 00 ⇒ The first group
- 01 ⇒ The second group
- 02 ⇒ The third group
- ⋮

EX: RS02LO<CR> <LF> Show "LO" presetting value

ANS: RS02LOXXXXXX<CR> <LF>

Command Format C

Host	Command+ Data
Slave	Command+ Data

Write weight comparison setting value WS○○□□XXXXXX

○○: Groups(00 ~ 09) □□: Setting Items XXXXXX: Setting Value

HI	Write "HI" setting value
LO	Write "LO" setting value

Note : ○○ (Group) is various depended on different models

- 00 ⇒ The first group
- 01 ⇒ The second group
- 02 ⇒ The third group
- ⋮

EX: WS00HI001000<CR> <LF> Write "HI" setting value

ANS: WS00HI001000<CR> <LF>

Set pre-tare weight value:

PT,○○○○○○○<CR> <LF> (○○○○○○○means weight)

To set pre-tare weight of 1kg while zero display as 0.000kg, give the following commands:

PT,001000

To cancel pre-tare, give the following commands: PT,000000

Error messages:

ND means the weight value is not in valid divisions

If the Scale's division is 5,the last digit of weight input must be 5 or 0.

NG means the weight value is over max capacity

NN means the weight value is non-numeric



Command Format D

Host Data
 Slave _____

Value (e.g. Price)						Position of decimal point	CR	LF
1	2	3	4	5	6	1		

When the Slave receives this data format, it will transfer the data and display it on its LCD.



12345.6

- ☞ The function is effective when the weight value is over 0.
- ☞ The above 4 (ABCD) command formats are RS232 bi-directional. There are the following error messages received by Slave terminal (scale).

Error messages:

- E1: Wrong command
- E2: Command format error (Wrong parameters)
- E3: Command not recognised

☞ Output data format

1. 7 places (first decimal place not included)

Weight format

Gross	S	T	,	G	S	,	+	0	1	2	3	4	5	6	7	SP	SP	o	z	CR	LF
Net	S	T	,	N	T	,	+	1	.	2	3	.	4	5	6	t	l	.	g		
Tare	S	T	,	T	R	,	+	0	1	2	.	3	4	5	6	SP	SP	k	g		
Plus OL	O	L	,	G	S	,	+	SP	SP	SP	SP	SP	SP	SP	SP	SP	SP	SP	SP		
Minus OL	O	L	,	G	S	,	-	SP	SP	SP	SP	SP	SP	SP	SP	SP	SP	SP	SP		
Unstable	U	S	,	G	S	,	+	0	1	2	3	4	.	5	6	SP	SP	l	b		

Weight format (OIML)

Gross	S	T	,	G		,	+	0	1	2	3	4	5	6	7	SP	SP	o	z	CR	LF
Net	S	T	,	N		,	+	1	.	2	3	.	4	5	6	t	l	.	g		
Tare	S	T	,	T		,	+	0	1	2	.	3	4	5	6	SP	SP	k	g		
Plus OL	O	L	,	G		,	+	SP	SP	SP	SP	SP	SP	SP	SP	SP	SP	SP	SP		
Minus OL	O	L	,	G		,	-	SP	SP	SP	SP	SP	SP	SP	SP	SP	SP	SP	SP		
Unstable	U	S	,	G		,	+	0	1	2	3	4	.	5	6	SP	SP	l	b		

Simple format

G/N	+	1	.	2	3	.	4	5	6	CR	LF
G/N	+	0	1	2	3	4	5	.	6		
G/N	+	0	1	2	.	3	4	5	6		
Plus OL	+	SP	SP	SP	SP	SP	SP	SP	SP		
Minus OL	-	SP	SP	SP	SP	SP	SP	SP	SP		



Comparison status + Simple format

Byte0	Byte1	Byte2	+/-	1	.	2	3	.	4	5	6	CR	LF
-------	-------	-------	-----	---	---	---	---	---	---	---	---	----	----

Byte0 : HI 30H/31H
 Byte1 : OK 30H/31H
 Byte2 : LO 30H/31H

2. 6 places (first decimal place not included)

Weight format

Gross	S	T	,	G	S	,	+	1	2	3	4	5	6	7	SP	SP	o	z	CR	LF
Net	S	T	,	N	T	,	+	.	2	3	.	4	5	6	t	l	.	g		
Tare	S	T	,	T	R	,	+	1	2	.	3	4	5	6	SP	SP	k	g		
Plus OL	O	L	,	G	S	,	+	SP	SP	SP	SP	SP	SP	SP	SP	SP	SP	SP		
Minus OL	O	L	,	G	S	,	-	SP	SP	SP	SP	SP	SP	SP	SP	SP	SP	SP		
Unstable	U	S	,	G	S	,	+	1	2	3	4	.	5	6	SP	SP	l	b		

Weight format (OIML)

Gross	S	T	,	G		,	+	1	2	3	4	5	6	7	SP	SP	o	z	CR	LF
Net	S	T	,	N		,	+	.	2	3	.	4	5	6	t	l	.	g		
Tare	S	T	,	T		,	+	1	2	.	3	4	5	6	SP	SP	k	g		
Plus OL	O	L	,	G		,	+	SP	SP	SP	SP	SP	SP	SP	SP	SP	SP	SP		
Minus OL	O	L	,	G		,	-	SP	SP	SP	SP	SP	SP	SP	SP	SP	SP	SP		
Unstable	U	S	,	G		,	+	1	2	3	4	.	5	6	SP	SP	l	b		

Simple format

G/N	+	.	2	3	.	4	5	6	CR	LF
G/N	+	1	2	3	4	5	.	6		
G/N	+	1	2	.	3	4	5	6		
Plus OL	+	SP	SP	SP	SP	SP	SP	SP		
Minus OL	-	SP	SP	SP	SP	SP	SP	SP		

Comparison status + simple format

Byte0	Byte1	Byte2	+/-	.	2	3	.	4	5	6	CR	LF
-------	-------	-------	-----	---	---	---	---	---	---	---	----	----

Byte0 : HI 30H/31H
 Byte1 : OK 30H/31H
 Byte2 : LO 30H/31H

☰ Switch between old and new (OIML) formats: Press and hold **M+/PRINT** key to turn on the scale, and when the display oLd/nEW appear for 2 seconds, release it to restart the scale nEW (OIML):

Gross	S	T	,	G		,	+	1	2	3	4	5	6	7	SP	SP	o	z	CR	LF
-------	---	---	---	---	--	---	---	---	---	---	---	---	---	---	----	----	---	---	----	----

oLd:

Gross	S	T	,	G	S	,	+	1	2	3	4	5	6	7	SP	SP	o	z	CR	LF
-------	---	---	---	---	---	---	---	---	---	---	---	---	---	---	----	----	---	---	----	----



Serial Data Transfer/Receive Format

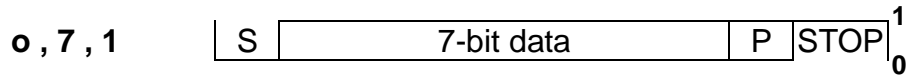
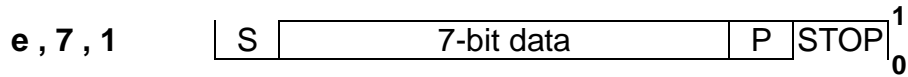
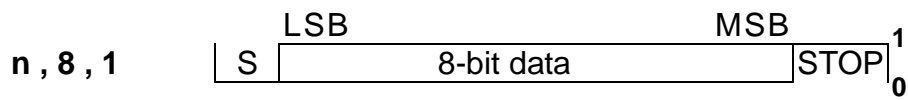

Note:

S : Start bit

STOP: Stop bit



P : Parity bit



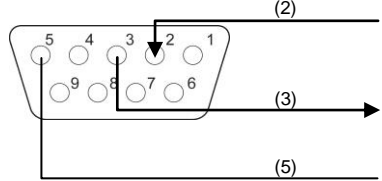

Appendix 4 Wiring Instructions

RS232 wiring instruction

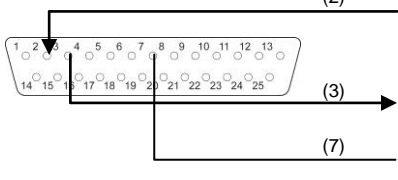

To connect RS232, please open the housing, RS232's PIN connectors locate on the bottom-right corner of the main board. The most common connection method is using 9PIN and 25PIN, as shown below:



PC	PIN	PC PIN Function	Female 9 PINS (PC PIN)	QW/GW PIN	QW/GW
	2	Receive Data (from QW/GW)		TxD	
	3	Transmit Data (to QW/GW)		RxD	
	5	Signal Ground		SG	

Printer	PIN	Printer PIN Function	Male 25 PINS (Printer PIN)	QW/GW PIN	QW/GW
	2	Receive Data (from QW/GW)		TxD	
	3	Transmit Data (to QW/GW)		RxD	
	7	Signal Ground		SG	

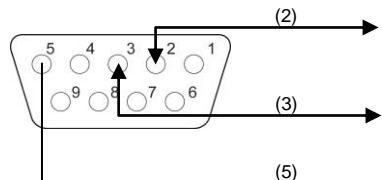
RS485 wiring instruction

To connect RS485, please make J17, J18 short and J15, J16 open on main board.

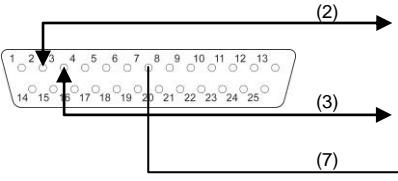
PC	PIN	PC PIN Function	Female 9 PINS (PC PIN)	QW/GW PIN	QW/GW
	2	Data I/O (half-duplex)		DB	
	3	Data I/O (half-duplex)		DA	
	5	Signal Ground		SG	

Printer	PIN	Printer PIN Function	Male 25 PINS (Printer PIN)	QW/GW PIN	QW/GW
	2	Data I/O (half-duplex)		DA	
	3	Data I/O (half-duplex)		DB	
	7	Signal Ground		SG	

To use other connection methods, please identify the signal and following the above principles. After it is finished, please assemble the housing by the instruction in the *SPECIAL NOTICE*.